



# **BUILT FOR WORLD'S BEST HORSES**

## **Product sheet: Mobile arena irrigation 20-30x60**

A dust free training environment and stable riding surface are essential for training your horses. Q-line® Dust development is a well known problem in riding arenas. Low humidity and intensive usage of the soil leads to dust and fine sand blowing up and through the arena. Training under these circumstances is not pleasant nor very healthy for horse and rider.

To counter this dust forming Q-line® has developed a number of irrigation systems. These system create an equal soil humidity in your arena. You never again have to worry about unhealthy sand and dust. The system can be set to operate automatically or can be controlled manually so that at any time you and your horse have the perfect foundation to ride on.

An equally sprayed foundation has a significantly longer life span and make it a better bottom to ride on. Q-line® utilizes special nozzles that create a mist that equally spreads over the arena.

The Q-line® irrigation systems are designed and build according to the highest norms and latest technological standards, where the safety and comfort for you and your horse come first.

Your arena, durable and free of dust with Q-line®

### **Unique benefits**

#### **Safety:**

The Q-line® horse irrigation systems water your riding surface equally so the foundation is the same consistency over the entire arena. This minimizes the chance your horse will fall.

#### **Durability:**

High quality materials and a solid construction make Q-line® irrigation systems a durable investment. The systems are equipped with an automatic draining system.

#### **External characteristics:**

The nozzles can be controlled from an easy to control box

#### **Maintenance:**

The Q-line® irrigation systems are solid constructions and requires little maintenance. Some systems our even automatically drained after use so they can't be damage when it freezes in the winter.

#### **Quality mark:**

All Q-Line® Irrigation conform to the machine code 2006/42/EG and are fit with the CE quality mark. The Q-line® solaria are certifiably approved by KEMA according to the NEN 3140 and ARBO directive en hereby conform to all European safety demands.





# **BUILT FOR WORLD'S BEST HORSES**

## **Product sheet: Mobile arena irrigation 20-30x60**

Optimal spreading of the sprinklers ensures an equally irrigated riding surface. Every sprinkler can be separately controlled so the irrigation can be focused on certain areas. This is particularly useful when some areas need to be dry faster than others.

Only the highest quality materials are used in the Q-line irrigation systems such as modern control systems. Our programmable control unit is very easy to use and is completely waterproof. The power and water supply run through a coiled hose package or optional through a cable chain. The control of the sprinklers is automatic as standard. Because barely any left over water is lost from the nozzles when the system is shut down, your arena can be used directly.

- ❑ Non ageing mist sprinklers
- ❑ Years proven electronic control
- ❑ Extremely robust
- ❑ Easy to use control
- ❑ Separate hoof path irrigation
- ❑ Perfect water spreading
- ❑ Can be implemented anywhere

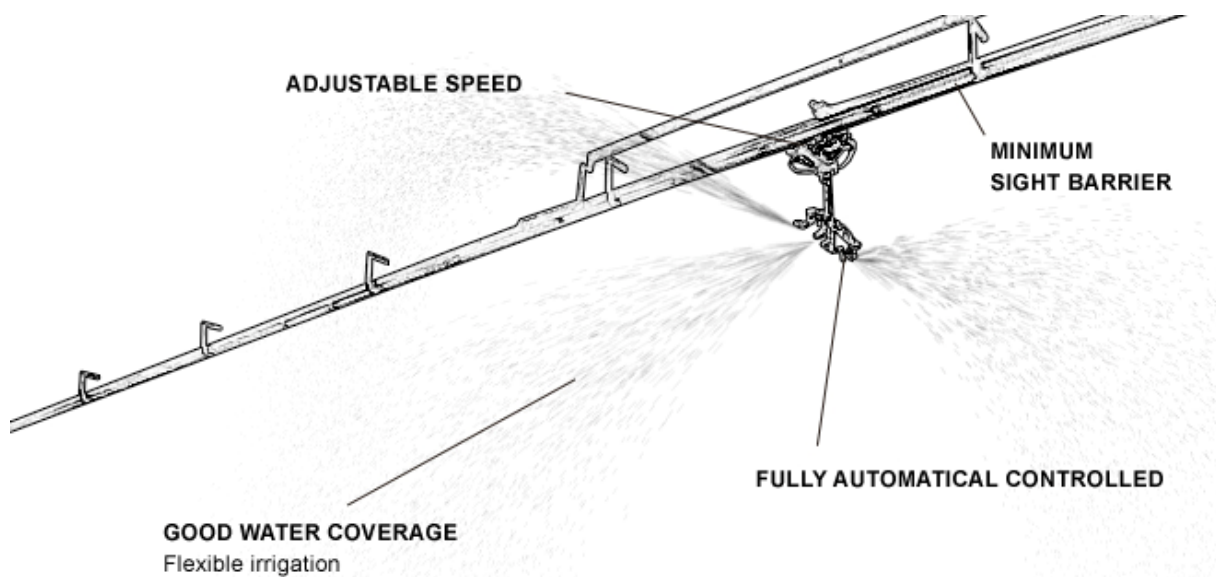



# **BUILT FOR WORLD'S BEST HORSES**

## ***Product sheet: Mobile arena irrigation 20-30x60***

### ***Technical specifications***

Art nr	PART3060
Width arena	20 to 30 meter
Length arena	80 meter
Number of sprinklers	6
Control	Automatic
Control box	1
Hose package	●
Industrial cable chain	○
Power connection	230V 50Hz
Electrical valves	6
Power	24V AC
Precipitation 2 mm	3600 liter in 23 min
Water usage	9,6m <sup>3</sup> /h
Operation pressure	3,5-4 bar
Required pump	6000 l/h

Standard ● , Optional ○

